

Presentation to:



**Institute of Fire Safety Managers**  
Annual General Meeting

Presented By:

**Steven Greenall**  
Operations Director  
M: 07887 708981 : E: [steven@user247.co.uk](mailto:steven@user247.co.uk)

**Mike Arch**  
Finance Director  
M: 07810 168988 : E: [mike@user247.co.uk](mailto:mike@user247.co.uk)

**User Limited**

**Tuesday, 6<sup>th</sup> October 2009**

Tel: 0247 7571 247 (Main Switchboard), 0247 7571 248 (Sales), [www.user247.co.uk](http://www.user247.co.uk)





**Our Mission & Values**

*To share responsibility for safety and well-being at home, at work and in our daily lives*

- To change the way people treat Health & Safety issues
  - By making it simpler and more accessible
  - To know what is safe and what may not be safe
- Create a safer environment for members of the public, customers and employees
- Remove the health and safety burden from one person and share it with users
  - Balancing the responsibility for safety across everyone
- Seeking partnerships which will deliver benefits in all areas of health & safety – both public and private sectors





The Concept

- Wherever there is an important need for a reminder, USER can be applied
  - Customer renewals
  - Regular inspections
  - Tests and measures
- The only visible, time-accurate and tamper proof reminder device available
  - Global patent pending
  - Completely innovative and unrivalled
- The product can be re-tailored
  - Timings
  - Appearance
  - Branding
  - Recycle
- It brings a **proactive** response to a **reactive** situation



# **USER**

How does it work?



This demo portrays a 12 month USER clock. Press Test to start, 3 lights will flash to indicate that the USER is activated.

1	2	3	4	5	6	7	8	9	10	11			
---	---	---	---	---	---	---	---	---	----	----	--	--	--



**USER :: Operational Criteria**

- **CE Certification**
- **Ingress Protection**
  - Liquid Intrusion: IPX6  
powerful jet-water proof in all directions
- **3V Lithium Manganese Dioxide Button Cell**
  - Nominal Voltage: 3V
  - Nominal Capacity: 210mAh
  - Recommended Continuous Drain: 0.2mA
  - Recommended Pulse Drain: 15mA
  - Standard Load: 15k $\Omega$
- **Crystal Specification**
  - Nominal Frequency :: 32.768 kHz
  - Frequency Tolerance (at 25 $^{\circ}$  C) :: +/- 20 ppm
  - Frequency Stability :: +/- 20 ppm
  - Operating Range :: -10 $^{\circ}$  C to + 60 $^{\circ}$  C
  - Aging (at 25 $^{\circ}$  C) :: 3 ppm / year
  - Fundamental Oscillation Mode
- **Unit Specification**
  - Up to 3 year maintenance-free battery
  - Minimum Unit size: 40 mm x 30 mm
  - Minimum Depth: 5mm

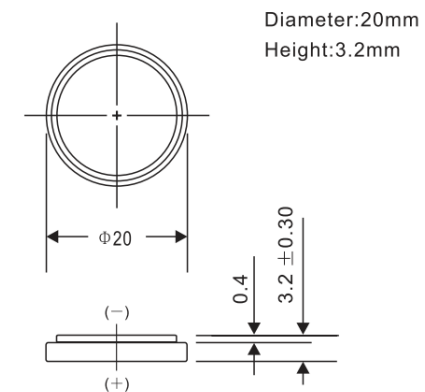
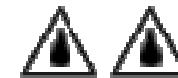

# **USER**

**USER @ Work**

- **TNT Global Express**

- On trial at Leicester Depot
- 6 weekly vehicle inspection
- 12 month MOT reminder



- **Jaguar Cars**

- Guy Salmon Main Dealers
- 12 month MOT reminder
- Customer retention & marketing



- **Sloane Helicopters**

- Annual Service Reminder
- Airworthiness Certificate
- LPC Pilot Check (keyring)



# **USER**

**USER :: Overview of Key Markets**

- **Transport**

- MOT Commercial
- 6 week O-Licence Inspections
- Aviation

- **Commercial**

- PAT Testing (portable equipment)
- LOLER Regs
- Equipment Servicing
- Fire Extinguisher Service

- **Home**

- Smoke Alarm Battery
- MOT Reminder
- Boiler Servicing & Installations
- Home Appliances
- Dental (6 month)
- Veterinary





**USER :: MOT Reminders**

33m MOT tests p.a. 8m vehicles (25%) on the road without a current MOT  
1 million tests over 4 weeks late in 2007-8



“Are you prone to forgetting things? Even important things - like the date of your car’s MOT? Then here’s a clever little gadget that costs peanuts and should sort you out.”

“We were very impressed by this device and decided that anything which prompts drivers to have their cars MOT’d in a timely fashion is something which we should support.”



- ✓ Reminder is in the actual vehicle
- ✓ Constantly reminds driver that action is needed
- ✓ Tamperproof and Non-resetable (but recyclable)
- ✓ Flashing Red LEDs alert law enforcement or inspectors
- ✓ Revenue Protection & Customer Retention
- ✓ Low Cost Solution
- ✓ For people who generally forget, takes away the burden
- ✓ Ultimately, it will take *dangerous* vehicles off the road and save lives

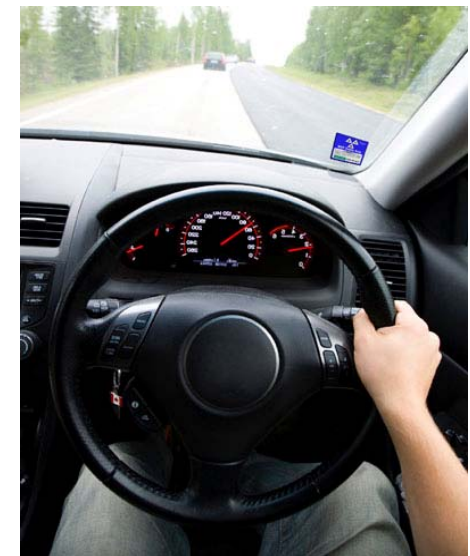

# **USER**

**USER :: Fire Safety**

### Smoke Alarm Battery Reminder

- ✓ 2007/8 :: 41,292 Fires Attended in Dwellings<sup>1</sup>
  - ✓ BV209i (Smoke Alarm Fitted & Activated) :: 17,431 (42%)
  - ✓ BV209ii (Smoke Alarm Fitted & Not Activated) :: 5,614 (14%)
  - ✓ BV209iii (No Smoke Alarm Fitted) :: 18,246 (44%)
- ✓ “In those dwelling fires where a smoke alarm was present, 31% of alarms in 2007 failed to operate”<sup>2</sup>
- ✓ “The main reason for smoke alarms failing to activate in battery-powered alarms was missing or flat batteries. In 2007 they accounted for 47 per cent of all failures in battery-powered alarms.”<sup>2</sup>



### Portable Fire Extinguisher Recharging & Maintenance

- ✓ Estimated 7m units requiring *at least* an annual service
- ✓ Oct 2006 – Oct 2008 :: 42 prosecutions for failing to comply with Fire Safety Order and 3,800 enforcement notices<sup>3</sup>
- ✓ “A landlord was ordered to pay more than £10,000 in fines and costs following a fire at a house of multiple occupation. Fire safety inspectors found that the fire alarm was not functioning and the main exit was obstructed. Fire doors were unserviceable due to missing or broken parts and the **fire extinguishers were past their testing dates.**”<sup>3</sup>

### Regular Service Reminders

- ✓ Hose Reels
- ✓ Suppression Systems
- ✓ Automatic Door Release
- ✓ Private Fire Hydrants
- ✓ Ancillary Fire Fighting Equipment

<sup>1</sup> Best Value Performance Indicators for 2007-08 (DCLG, Aug 2009)

<sup>2</sup> UK Fire Statistics 2007 Revised (DCLG, Aug 2009)

<sup>3</sup> Fire Protection Association (FPA) Fire Risk Management Journal



# **USER**

**USER :: The Future**

- Solar Powered
- Bluetooth
- Circuit Integration
- Ribbon – Printed Circuit Board (PCB)
- RFID – Radio Frequency Identification Technology





**USER :: Q&A Session**

A digital copy of today's presentation is available from:

**Steven Greenall**  
Operations Director  
M: 07887 708981  
E: [steven@user247.co.uk](mailto:steven@user247.co.uk)

**User Limited**

Tel: 0247 7571 247 (Main Switchboard), 0247 7571 248 (Sales), [www.user247.co.uk](http://www.user247.co.uk)

